

AUTO-CATEGORIZATION

WHAT AGENCIES NEED TO KNOW

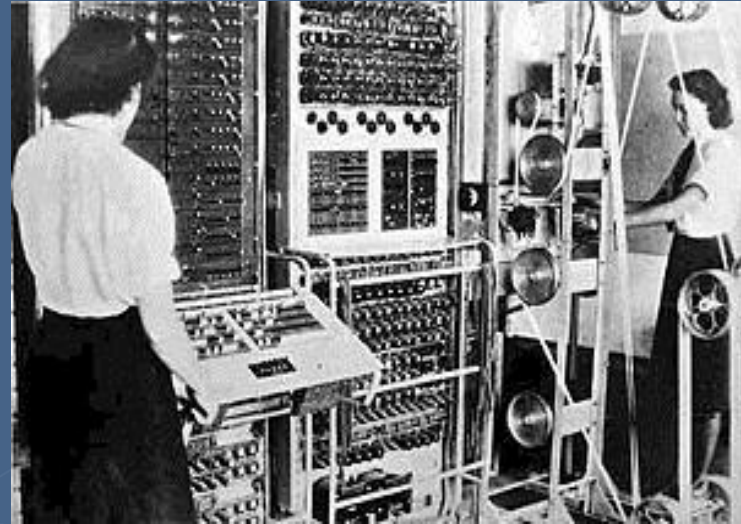

Tom Edwards

FEITH SYSTEMS AND SOFTWARE, INC.

TOM@FEITH.COM

MARCH 15TH 2012

Good Government Requires Good Recordkeeping **FEITH**



Agenda

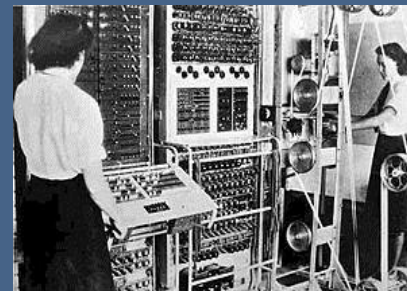

- Auto-Categorization
- Impediments to Automation
- The Way Forward



Auto-Categorization

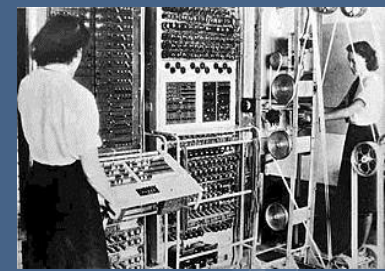

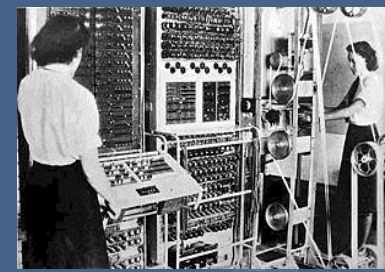

How are we doing?



Auto-Categorization Today

How are We Doing?

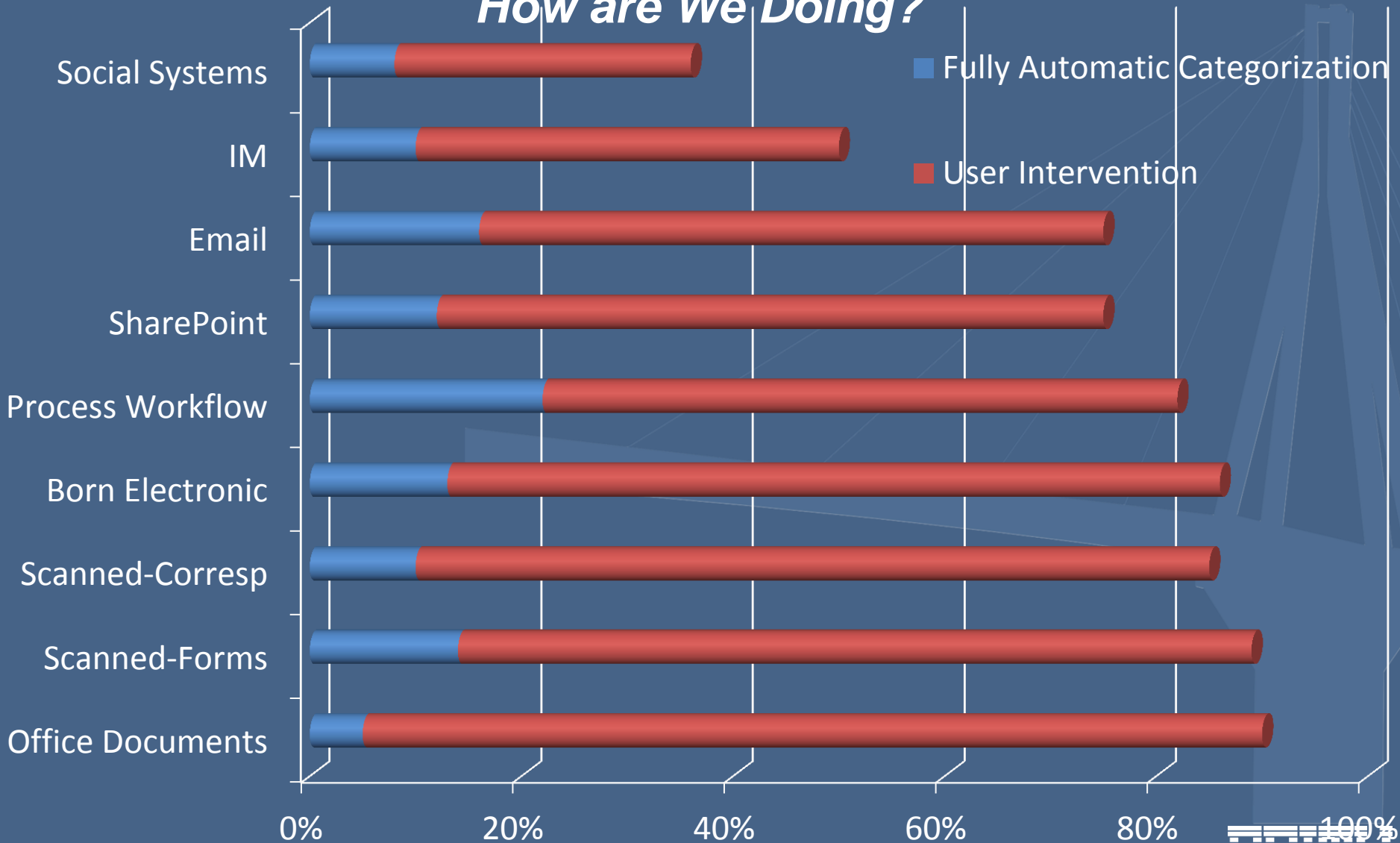

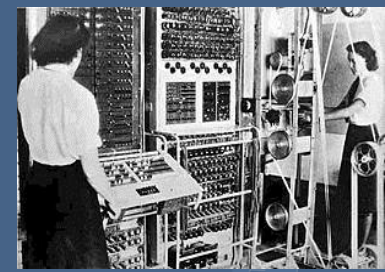

Where does Auto-Categorization Fit?



Records Management Flow Diagram



Reports



Dashboards

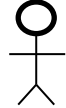

eDiscovery

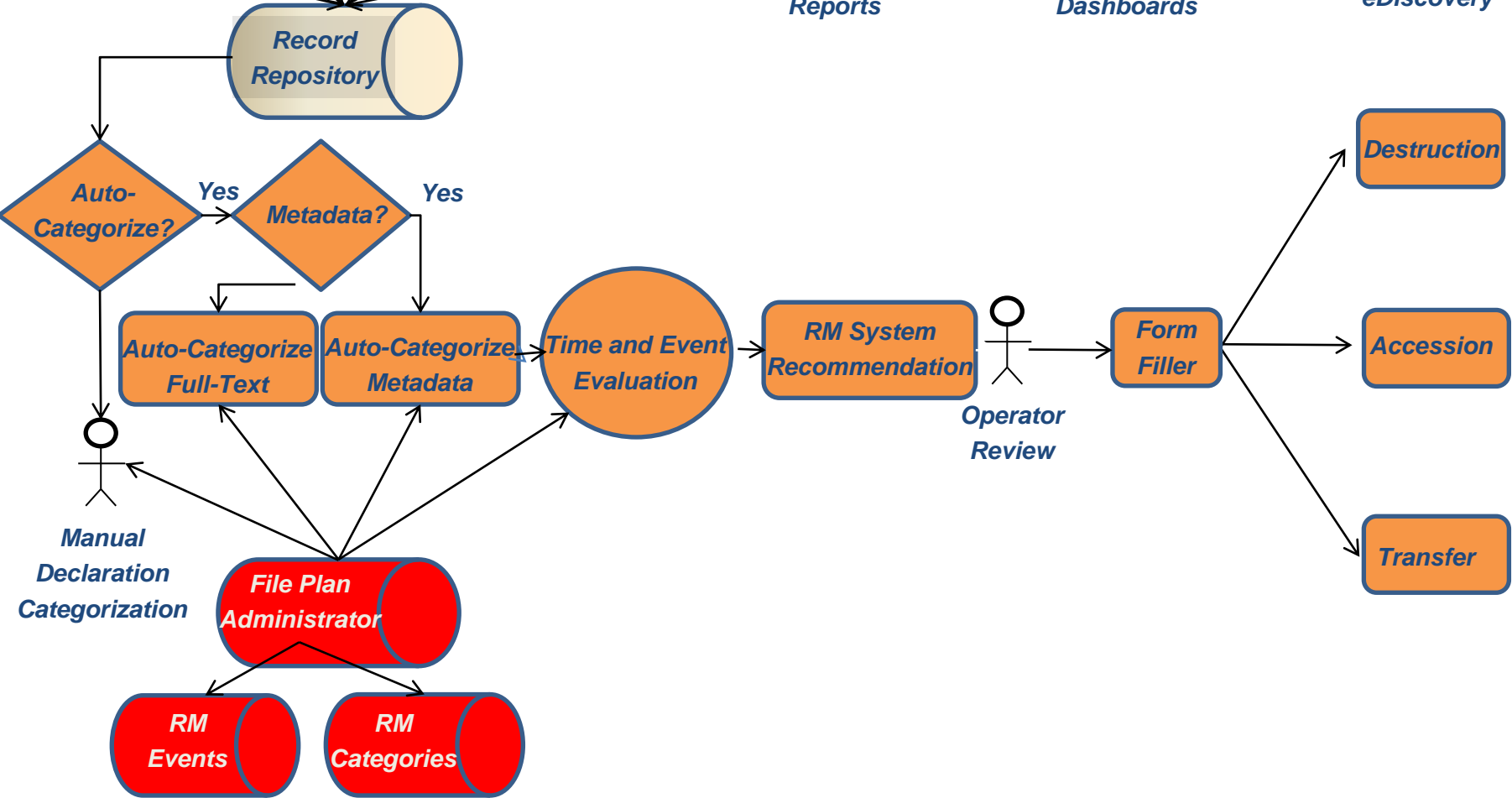

Auto-Categorization “Tooth” vs. “Tail”

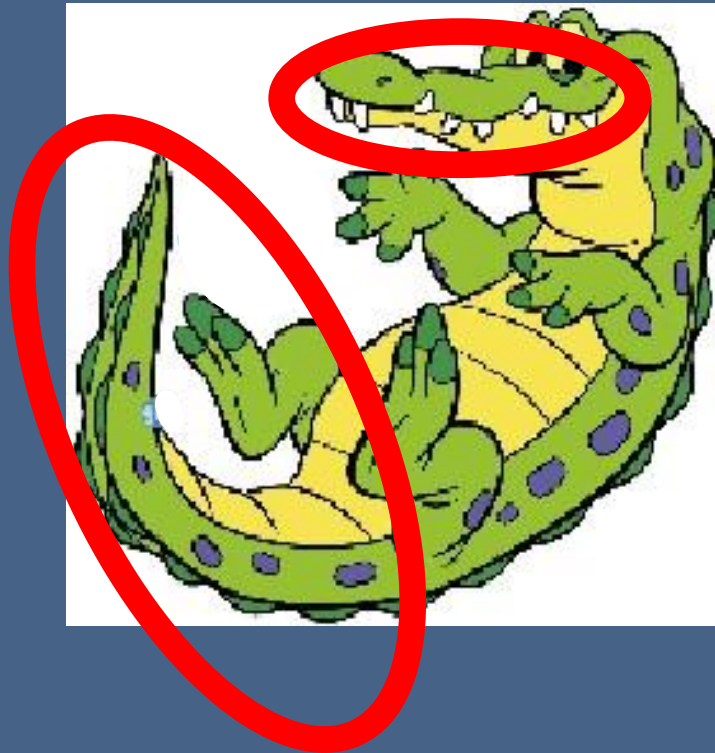

When to Automate Categorization

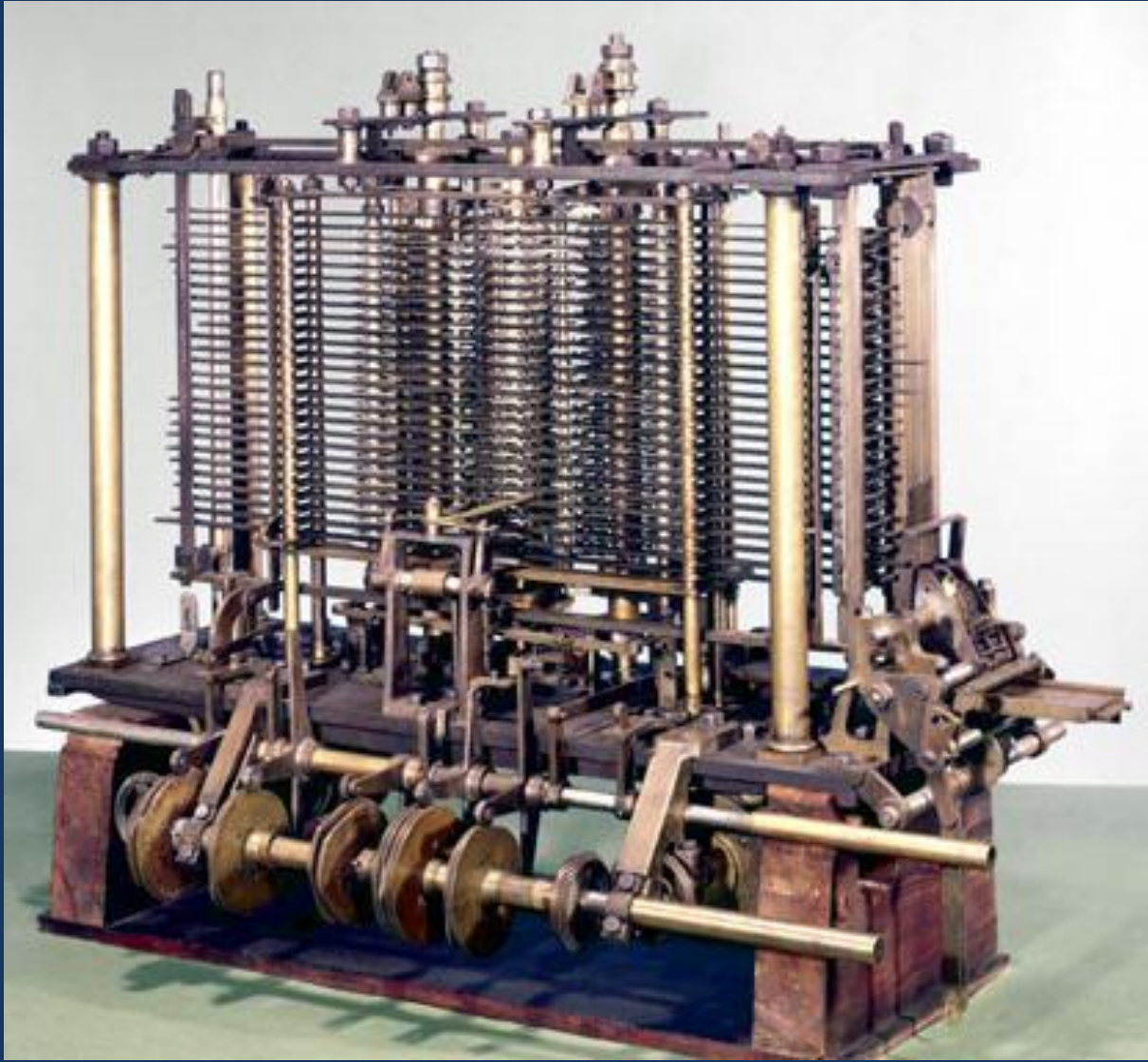

"ANOTHER AGE MUST BE THE JUDGE"
— Charles Babbage 1837

**Charles
Babbage
1849**

When to Automate Categorization

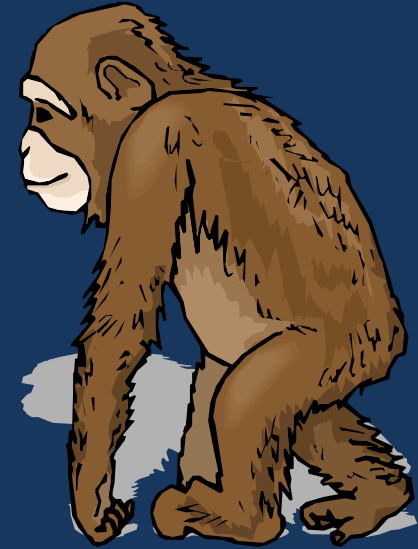
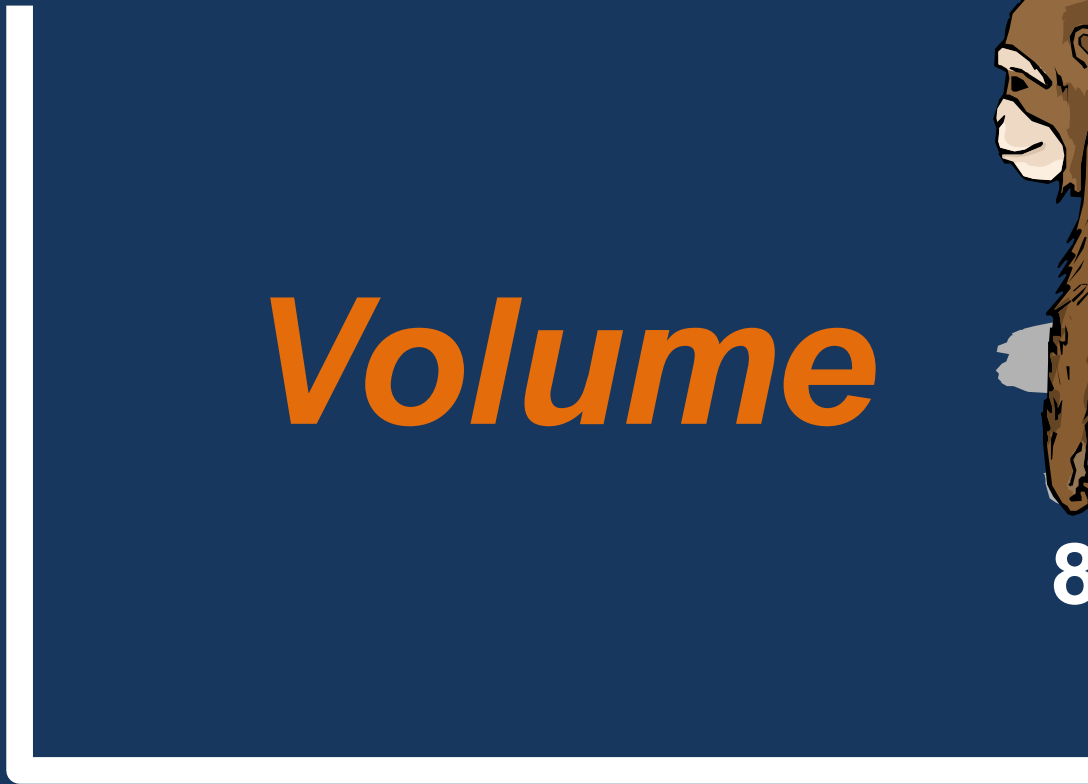

800 lbs.



When to Automate Categorization

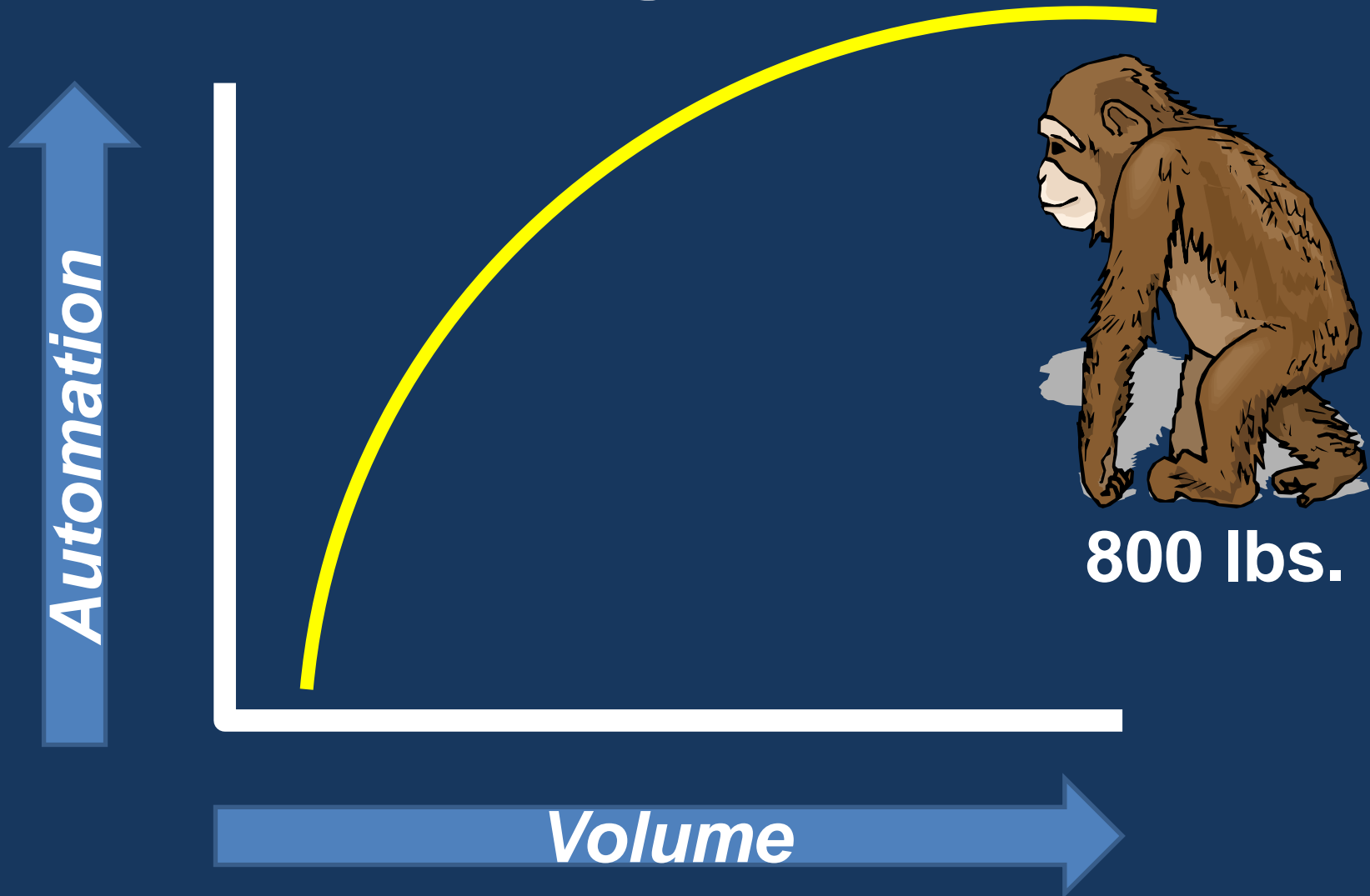



Auto-Categorization Methods

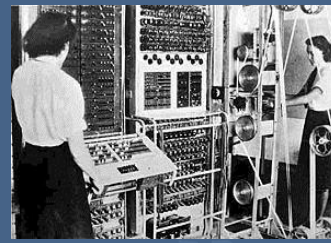

Full-Text

Metadata



DD Form	
1610	
[Small text and fields]	



Auto-Categorization

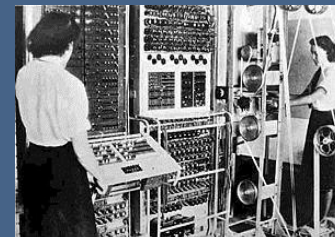

Full-Text



Accuracy



Cost



- **Supervised Learning**
 - **Bayesian, Neural Networks, kNN, SVM**
- **Unsupervised Learning**
- **Pattern Matching**



Auto-Categorization

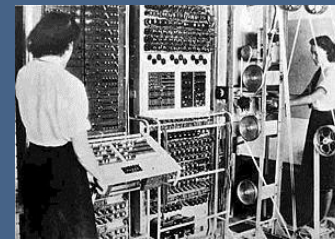

Full-Text



Metadata



DD Form	
1610	
[Form fields and text]	



Auto-Categorization

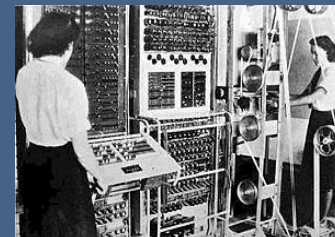

Metadata

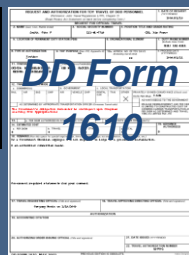

Accuracy



Cost

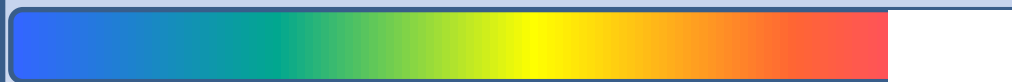

- Keyed-In
- Personnel Solution
- Barcodes
- Enterprise Resource Program
- Doc Properties
- Line-of-Business System
- Workflow System

When to Automate Categorization



When to Automate Categorization

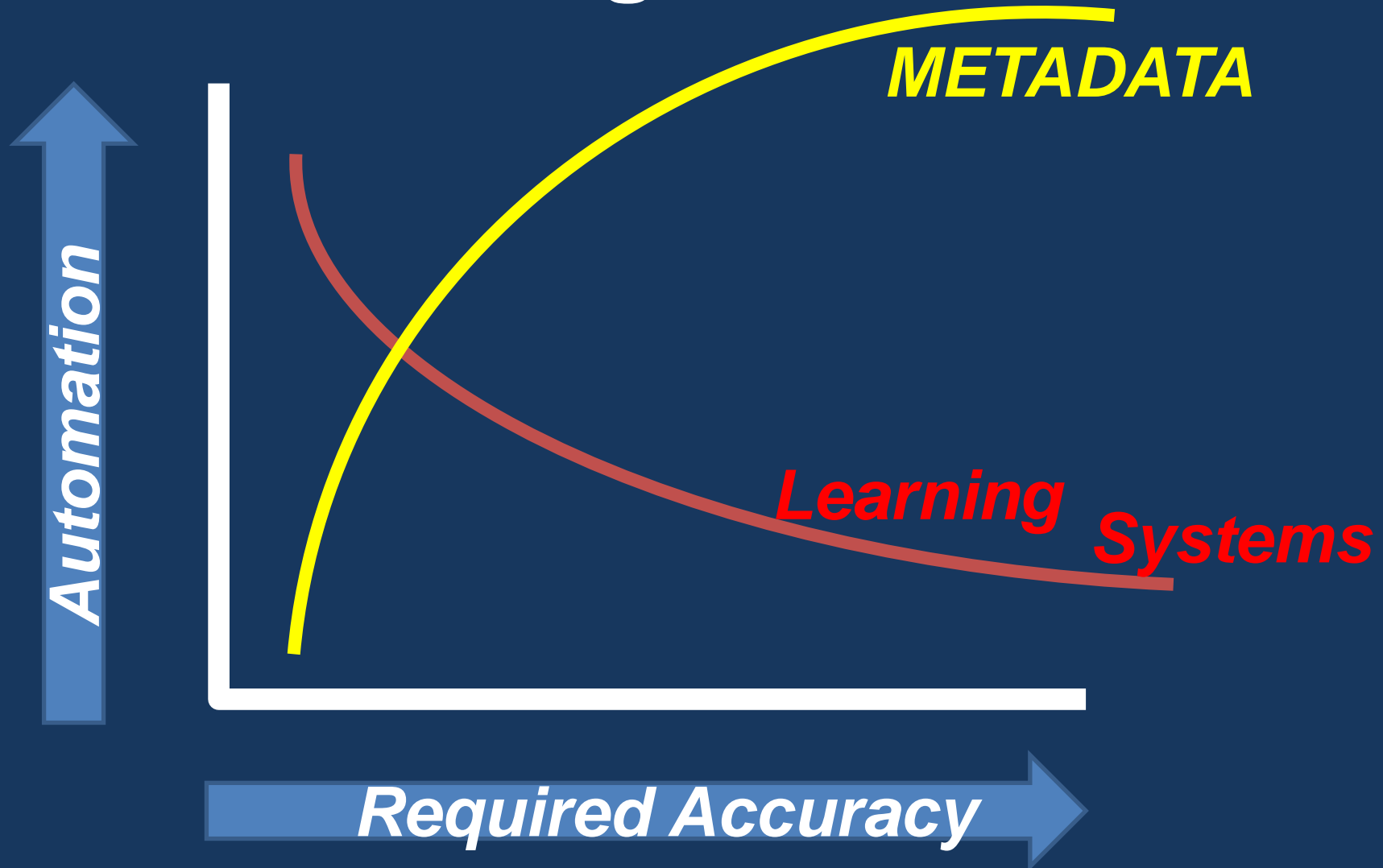



Auto-Categorization Methods

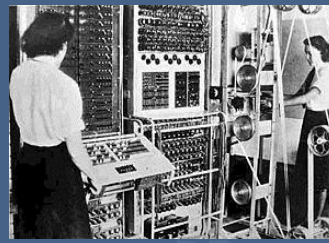

Full-Text

Metadata



DD Form	
1610	
[Small text and fields]	



Impediments to Automation

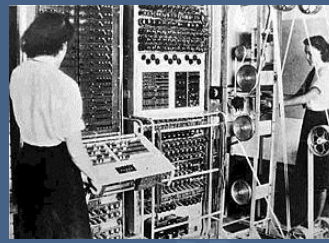

- Numerous Rules
- Automation Unfriendly Rules
- Events

Numerous Rules

GRS-14	Freedom of Information Act (FOIA)
1. <u>Information Requests Files.</u>	1 Destroy when 3 months old.
2. <u>Acknowledgment Files.</u>	2 Destroy 3 months after acknowledgment and referral.
3. <u>Press Service Files.</u>	3 Destroy when 3 months old.
4. <u>Information Project Files.</u>	4 Destroy 1 year after close of file or 1 year after completion of project.
5. <u>Commendation/Complaint Correspondence.</u>	5 Destroy when 3 months old.
6. <u>Indexes and Check Lists.</u>	6 Destroy when superseded or obsolete.
11.a.1. Granting access to all the requested records.	7 Destroy 2 years after date of reply.
11.a.1.2 Requests for nonexistent records; inadequate descriptions; and to those who fail to pay agency reproduction fees. (a) Request not appealed.	8 Destroy 2 years after date of reply.
(b) Request appealed.	9 Destroy as authorized under Item 12.
11.a.1.3 Denying all/part of the record requested.	
(a) Request not appealed.	10 Destroy 6 years after date of reply.
(b) Request appealed.	11 Destroy as authorized under Item 12.



Numerous Rules

GRS-14	Freedom of Information Act (FOIA)
b. Official file copy of requested records.	Dispose of in accordance with approved agency disposition instructions for the related records or with the related FOIA request, whichever is later.
12. <u>FOIA Appeals Files</u> . a. Correspondence and supporting documents	Destroy 6 years after final determination by agency, 6 years after the time at which a requester could file suit, or 3 years after final adjudication by the courts, whichever is later.
b. Official file copy of records under appeal.	Dispose of in accordance with approved agency disposition instructions for the related record or with the related FOIA request, whichever is later.
13. <u>FOIA Control Files</u> . a. Registers or listing.	Destroy 5 years after date of last entry.
b. Other files.	Destroy 5 years after final action by the agency or after final adjudication by courts, whichever is later
14. <u>FOIA Reports Files</u> .	Destroy when 2 years old.
15. <u>FOIA Administrative Files</u> .	Destroy when 2 years old.



Impediments to Automation

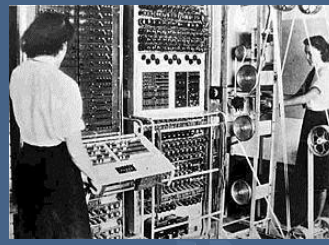

- Numerous Rules
- Automation Unfriendly Rules
- Events



Impediments to Automation

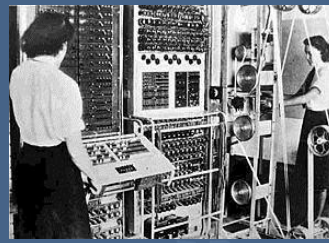

Divine vs. Predication

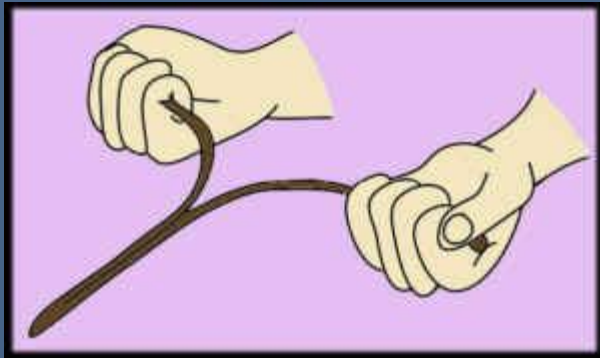

Divination

Exclusive Predication

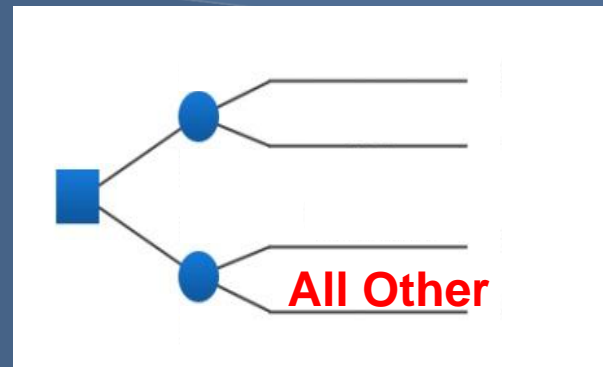

“All Other”

FEITH

Automation Unfriendly Rules

Email Categorization - Divination

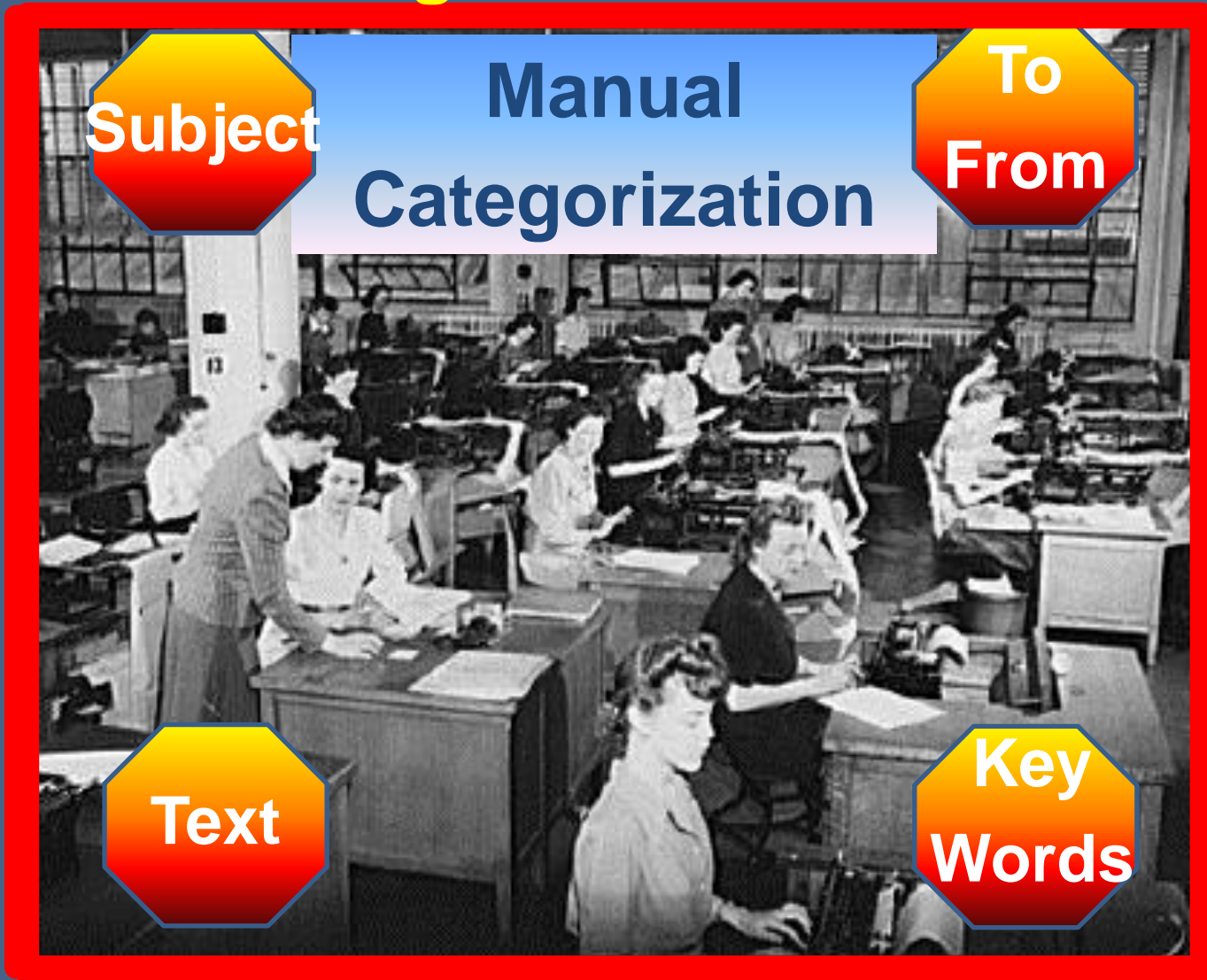

Auto-Categorization Divination

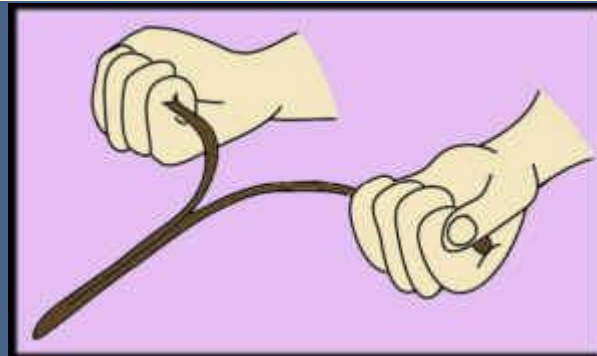
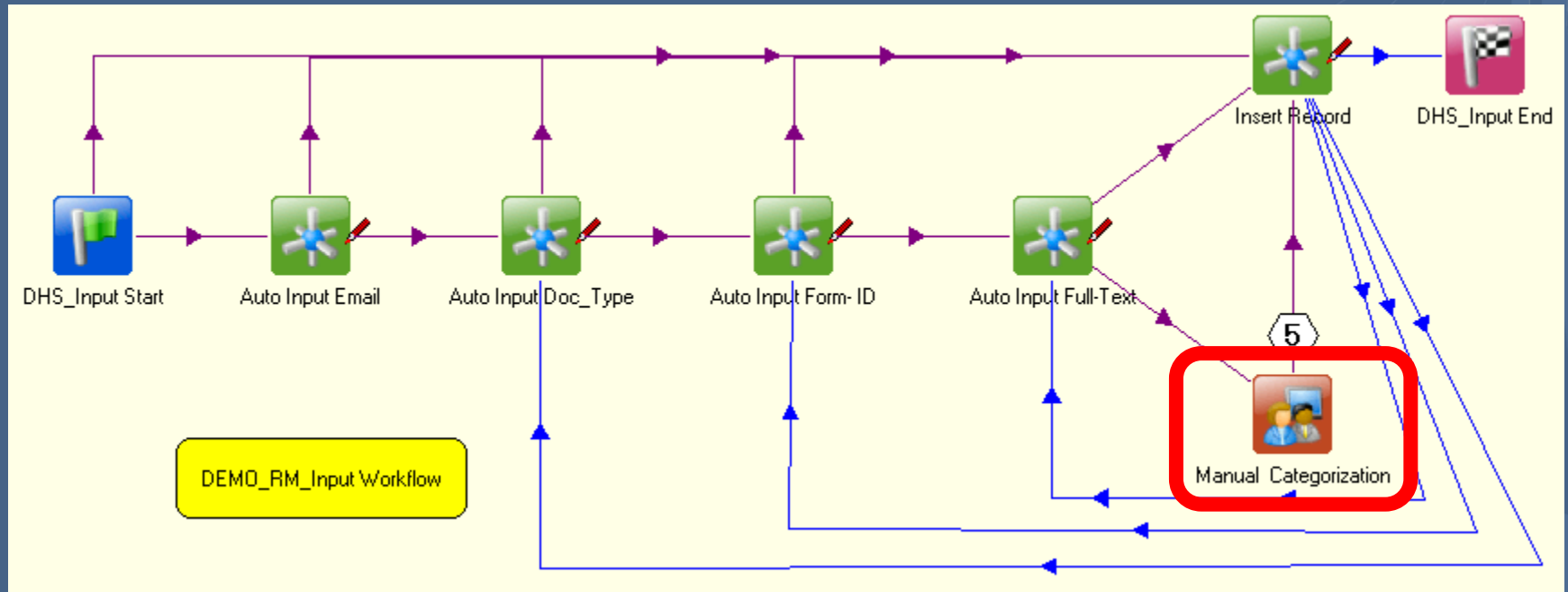

Auto-Categorization Exclusive Predication

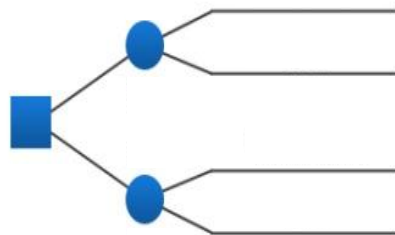
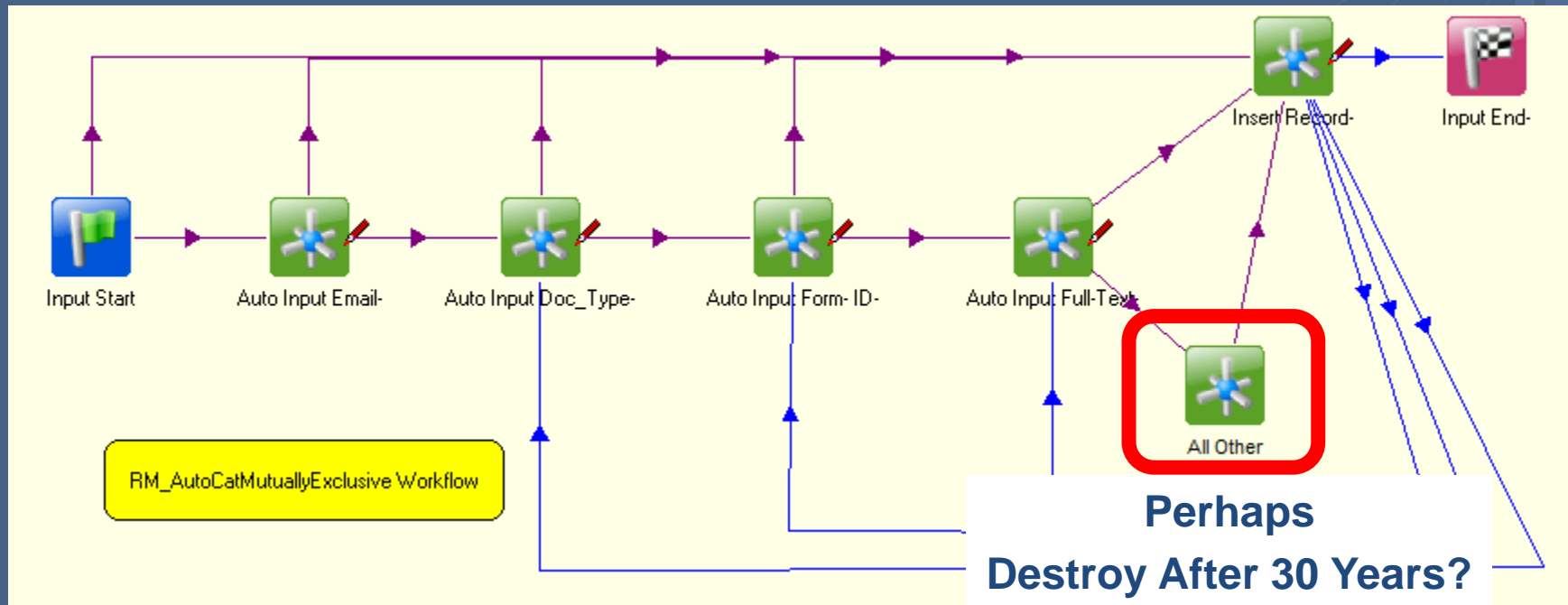

Automation Friendly Rules

Exclusive Predication

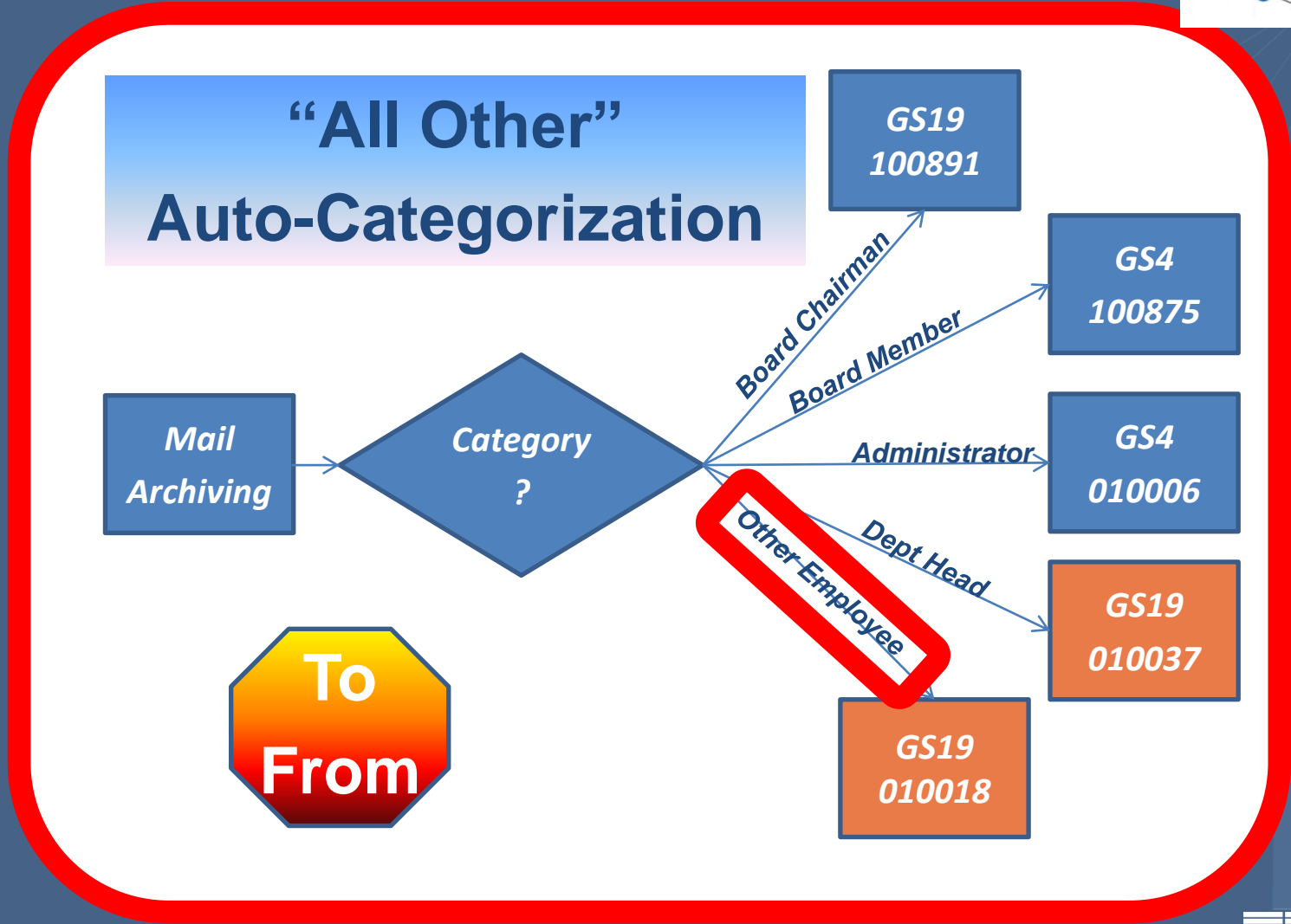
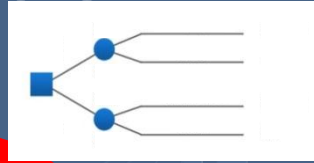

Automation Unfriendly Rules

GRS-1-21	<u>Employee Medical Folder (EMF).</u>
Long-term medical records (2) Separated employees.	<p><i>Transfer to NPRC, St. Louis, MO, 30 days after separation. NPRC will destroy 75 years after date of birth date or if date of birth is not known, 60 years after date of the earliest document, or 30 years after latest separation, whichever is later.</i></p>



Impediments to Automation

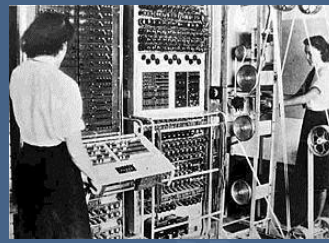

- Numerous Rules
- Automation Unfriendly Rules
- Events

General Records Schedules

Disposition Rules



Time Based



Event Based



Time and Event Based



General Records Schedules

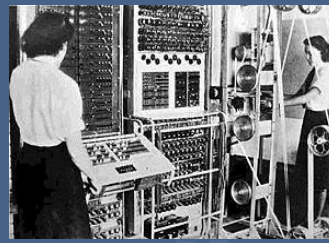

One to Many Event



Event

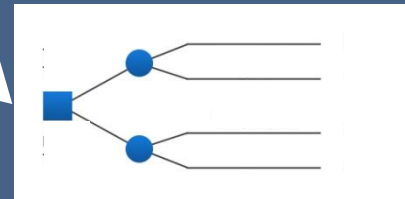
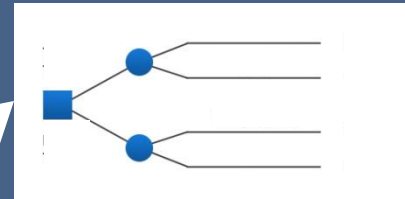

Rules



General Records Schedules

One to One Event



Event

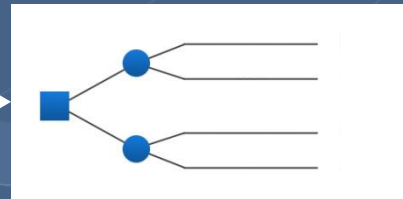

Rule



Record



General Records Schedules

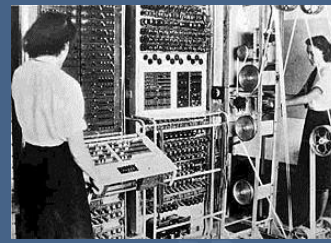

Automated vs. Manual Events

Automated

Retirement (Personnel System)

Fulfillment (Logistics System)

Case Closed (Case Management)

Email Thread (Exchange)

Asset Sold (ERP)

Doc Version (Doc Mgt System)

Manual

Superseded / Obsolete

No Longer Needed

Final Action

Completion

GAO Audit

Termination

Cancelation



General Records Schedules

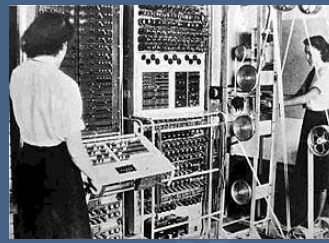

Time or Event Based

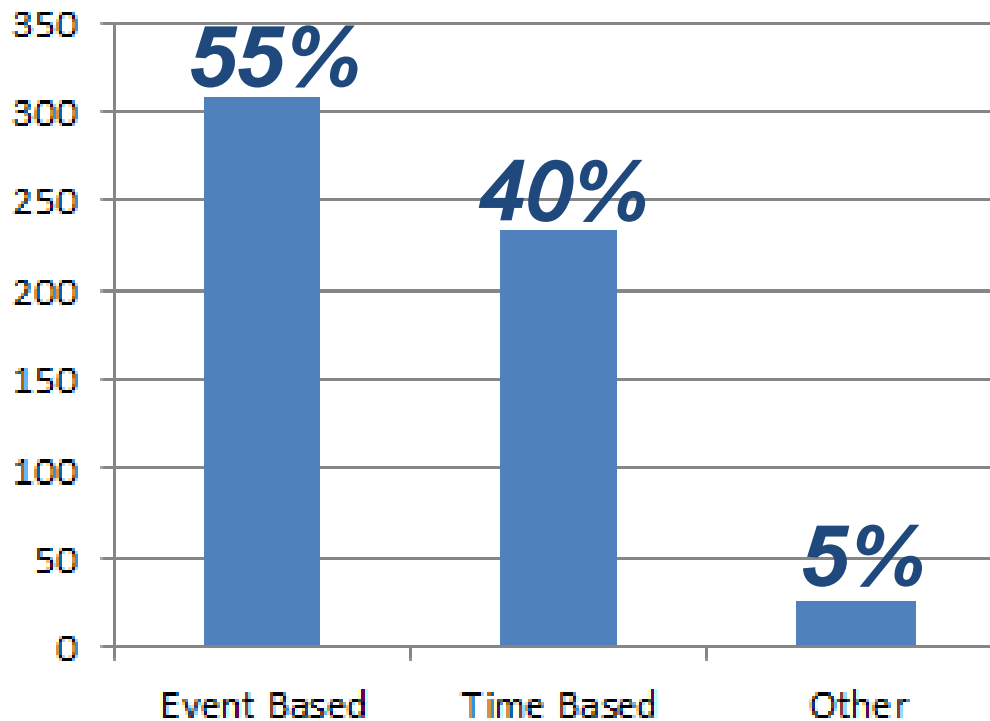

Automation Unfriendly Rules

Numerous Events

GRS-3-9.	<u>Inventory Files.</u>
b. Inventory cards.	
	<p>Destroy</p> <ul style="list-style-type: none">2 years after discontinuance of item or2 years after stock balance is transferred or2 years after transferred to new card or2 years after recorded under a new classification, or2 years after equipment removed from agency control

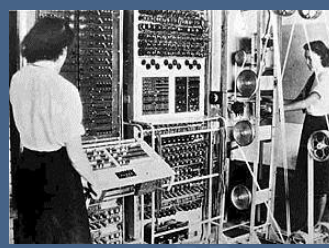

The Way Forward



Fewer Rules

GRS-14	Freedom of Information Act (FOIA)
1. <u>Information Requests Files.</u>	1 Destroy when 3 months old.
2. <u>Acknowledgment Files.</u>	2 Destroy 3 months after acknowledgment and referral.
3. <u>Press Service Files.</u>	3 Destroy when 3 months old.
4. <u>Information Project Files.</u>	4 Destroy 1 year after close of file or 1 year after completion of project.
5. <u>Commendation/Complaint Correspondence.</u>	5 Destroy when 3 months old.
6. <u>Indexes and Check Lists.</u>	6 Destroy when superseded or obsolete.
11.a.1. Granting access to all the requested records.	7 Destroy 2 years after date of reply.
11.a.1.2 Requests for nonexistent records; inadequate descriptions; and to those who fail to pay agency reproduction fees. (a) Request not appealed.	8 Destroy 2 years after date of reply.
(b) Request appealed.	9 Destroy as authorized under Item 12.
11.a.1.3 Denying all/part of the record requested.	
(a) Request not appealed.	10 Destroy 6 years after date of reply.
(b) Request appealed.	11 Destroy as authorized under Item 12.

Fewer Rules

GRS-14	Freedom of Information Act (FOIA)
b. Official file copy of requested records.	Dispose of in accordance with approved agency disposition instructions for the related records or with the related FOIA request, whichever is later.
12. <u>FOIA Appeals Files</u> . a. Correspondence and supporting documents	Destroy 6 years after final determination by agency, 6 years after the time at which a requester could file suit, or 3 years after final adjudication by the courts, whichever is later.
b. Official file copy of records under appeal.	Dispose of in accordance with approved agency disposition instructions for the related record or with the related FOIA request, whichever is later.
13. <u>FOIA Control Files</u> . a. Registers or listing.	Destroy 5 years after date of last entry.
b. Other files.	Destroy 5 years after final action by the agency or after final adjudication by courts, whichever is later.
14. <u>FOIA Reports Files</u> .	Destroy when 2 years old.
15. <u>FOIA Administrative Files</u> .	Destroy when 2 years old.

Buckets

GRS-14	Freedom of Information Act (FOIA)
1. <u>Information Requests Files.</u>	Destroy when 3 months old.
3. <u>Press Service Files.</u>	
5. <u>Commendation/Complaint Correspondence.</u>	
4. <u>Information Project Files.</u>	Destroy 1 year after close of file or 1 year after completion of project.
2. <u>Acknowledgment Files.</u>	Destroy 3 months after acknowledgment and referral
6. <u>Indexes and Check Lists.</u>	Destroy when superseded or obsolete.
11.a.1. Granting access to all the requested records.	Destroy 2 years after date of reply.
11.a.1.2 Requests for nonexistent records; inadequate descriptions; and to those who fail to pay agency reproduction fees. (a) Request not appealed.	
11.a.1.2(b) Request appealed.	Destroy as authorized under Item 12.
11.a.1.3(b) Request appealed.	
11.a.1.3 Denying all or part of the records requested	
(a) Request not appealed.	Destroy 6 years after date of reply.

Flexible Scheduling

GRS-14	Freedom of Information Act (FOIA)
1. <u>Information Requests Files.</u>	<div style="border: 2px solid #0056b3; border-radius: 25px; padding: 20px; text-align: center;"> <p>Destroy no earlier than 2 years, nor later than 6 years after date of reply.</p> </div>
2. <u>Acknowledgment Files.</u>	
3. <u>Press Service Files.</u>	
4. <u>Information Project Files.</u>	
5. <u>Commendation/Complaint Correspondence.</u>	
11.a.1. Granting access to all the requested records.	
11.a.1.2 Requests for nonexistent records; inadequate descriptions; and to those who fail to pay agency reproduction fees. (a) Request not appealed.	
11.a.1.3 Denying access to all or part of the records requested. (a) Request not appealed.	
(a) Request not appealed.	
(b) Request appealed.	
6. <u>Indexes and Check Lists.</u>	Destroy when superseded or obsolete.

Rules Designed to Leverage Automation

GRS-1-21	<u>Employee Medical Folder (EMF).</u>
Long-term medical records (2) Separated employees.	<p><i>Transfer to NPRC, St. Louis, MO, 30 days after separation. NPRC will destroy 75 years after date of birth date or if date of birth is not known, 60 years after date of the earliest document, or 30 years after latest separation, whichever is later.</i></p>
	<p><i>Transfer to NPRC, St. Louis, MO, 30 days after separation. NPRC will destroy 60 years after date of the earliest document.</i></p>

Fewer Events

GRS-3-9.	<u>Inventory Files.</u>
b. Inventory cards.	
	<p>Destroy</p> <ul style="list-style-type: none">2 years after discontinuance of item or2 years after stock balance is transferred or2 years after transferred to new card or2 years after recorded under a new classification, or2 years after equipment removed from agency control

2 years after stock no longer maintained

Rules Designed to Leverage Automation

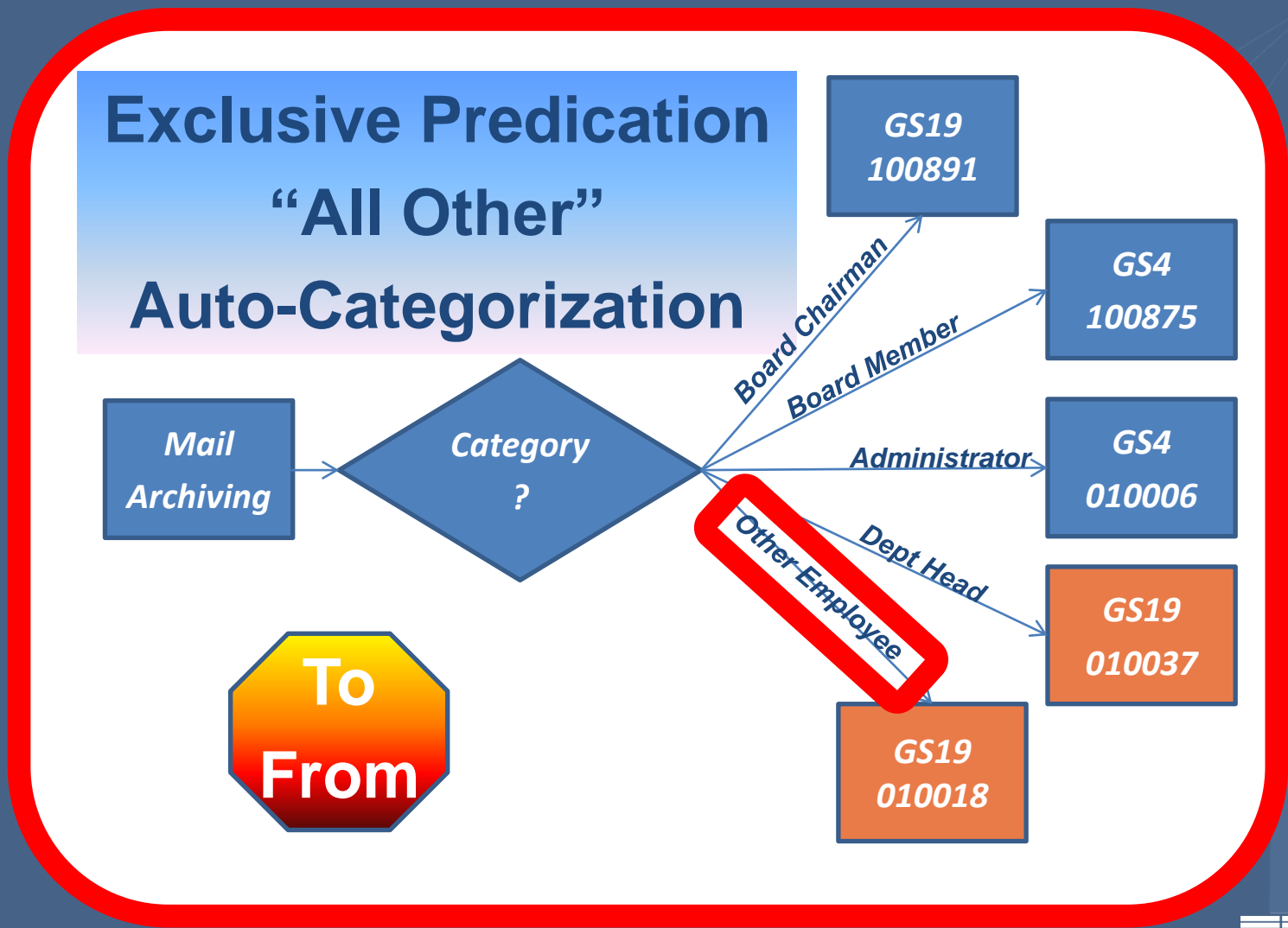

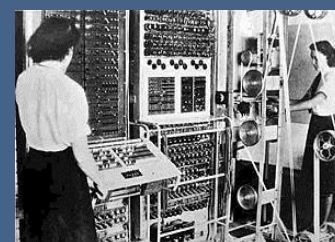

The Way Forward

Tell 'em What Ya Told 'em

- Automate (*Where it makes sense*)
- Modernize Guidance
 - Fewer Rules
 - Elimination/Consolidation
 - Buckets
 - Flexible Scheduling
 - Fewer Events
 - Rules Designed to Leverage Automation



AUTO-CATEGORIZATION

WHAT AGENCIES NEED TO KNOW

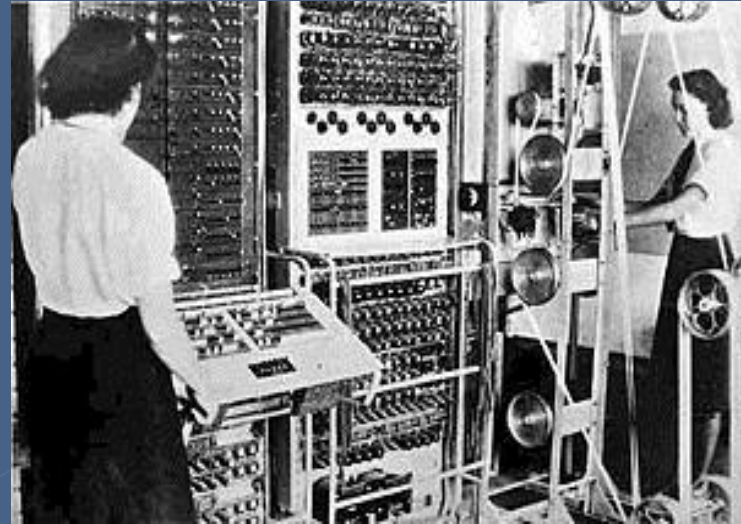

Tom Edwards

FEITH SYSTEMS AND SOFTWARE, INC.

TOM@FEITH.COM

MARCH 15TH 2012

Good Government Requires Good Recordkeeping **FEITH**